

# W40 FIRE

Steel is the ideal material for the realization of fire doors, thanks to its stability in the event of a fire. Associated to the correct fire-rated glass, it guarantees a secure barrier against fire and smoke.

W40 FIRE - with fire protection classes from E30 to E120 - offers a wide range of possibilities for finely dividing residential, commercial and institutional buildings into safe fire protection sectors.

Keeping the original manufacturing method of hot-rolling, W40 FIRE has an evocative and elegant design that meets the highest architectural demands, both for renovation works and contemporary buildings.

Fire out, beauty in



## CHARACTERISTICS

1. hot rolled steel profile - high precision production lines
2. solid profile with a thickness from 3 to 5 mm
3. both internal and external overlapping sightline
4. self-adhesive intumescent gaskets
5. glass installed according to the different protection classes
6. steel angular glazing beads
7. "natural steel" surface finish, for an industrial look of internal partitions, besides coating in any RAL or customized colours

drawing scale 1:1

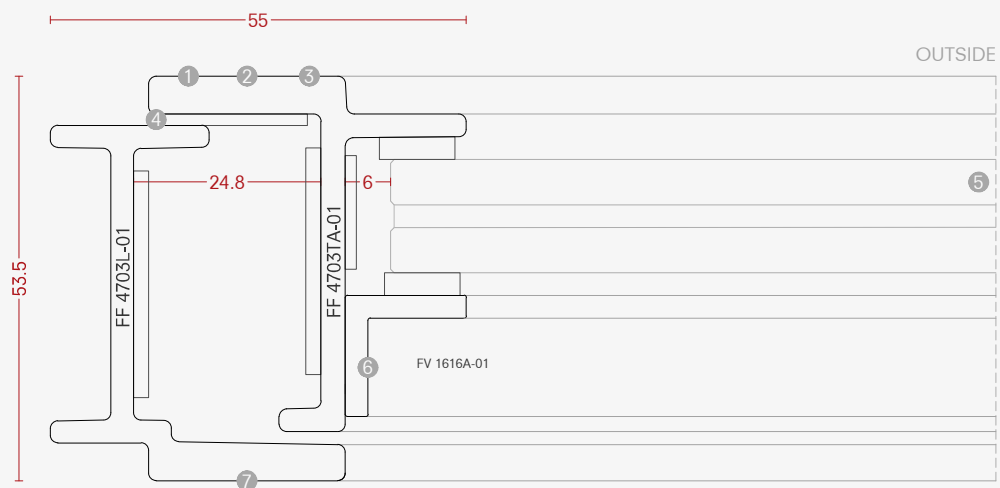

## W40 FIRE

### materials

Hot-rolled steel

---



glazing beads

1 - FV 1616A-01



## W40 FIRE

### hinges

C99008-12 (example on door)

---



opening types

1 - hinged door P. 294, 295 / 2 - hinged door P. 294, 295 / 3 - fixed P. 295  
 4 - fixed glazing with hinged door / 5 - curtain wall with hinged door

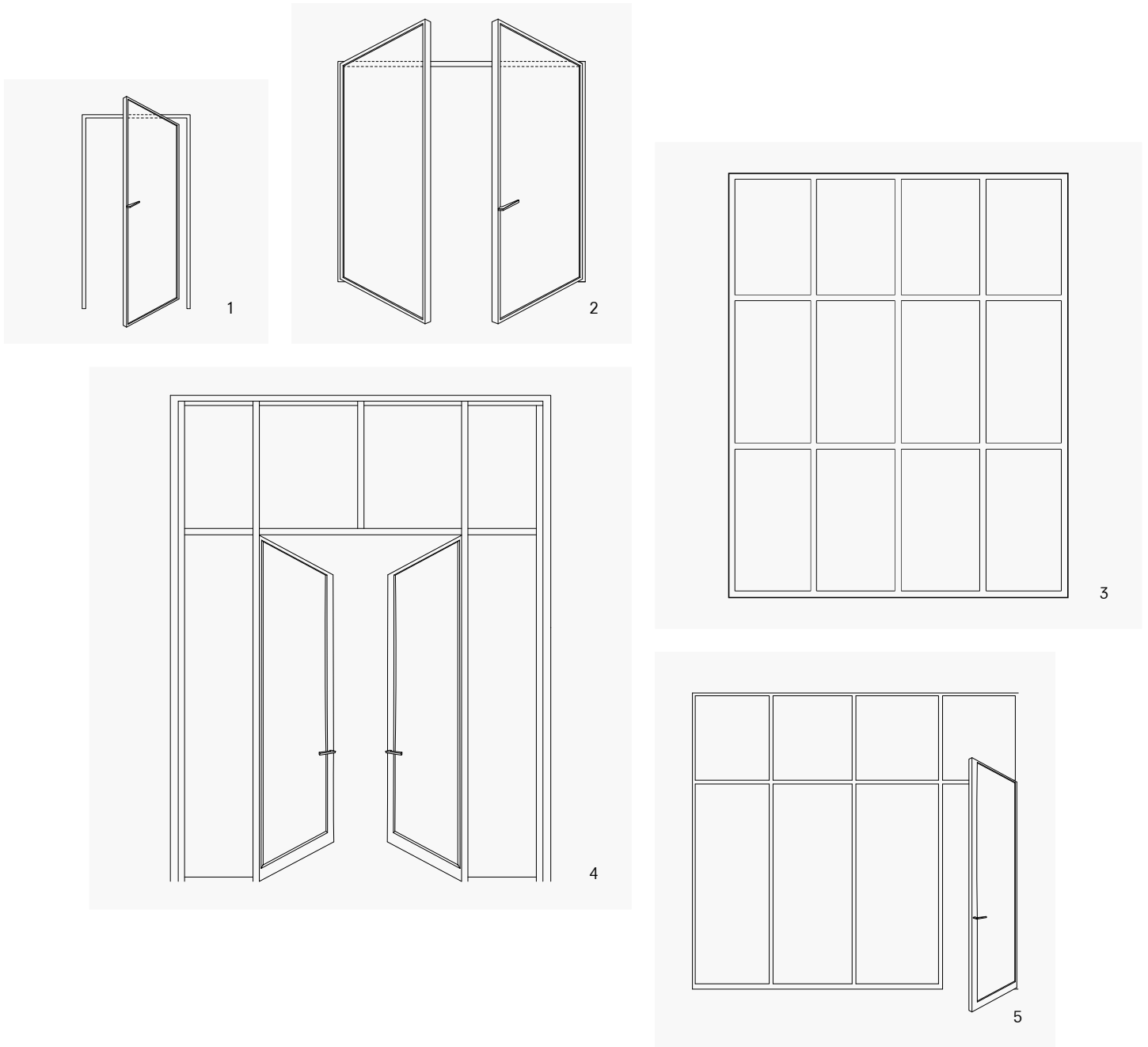

# W40 FIRE

profile range - bar length 5800 mm

-01 Hot rolled steel    -14 Laser welded and sand blasted steel

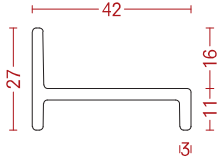

FF 4203LF-01

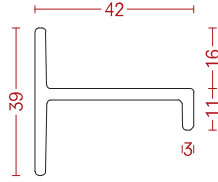

FF 4203TF-01

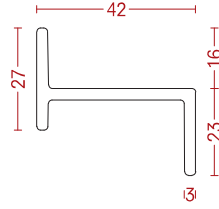

FF 4203ZF-01

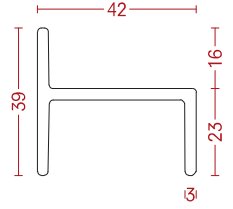

FF 4203HF-01

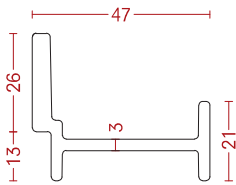

FF 4703L-01

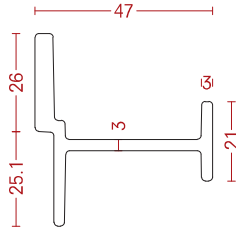

FF 4703T-01

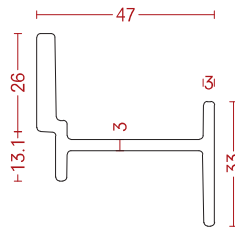

FF 4703Z-01

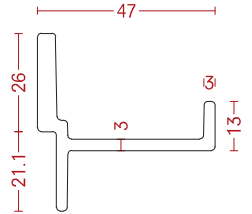

FF 4703TL-01

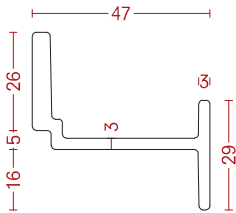

FF 4703ZL-01

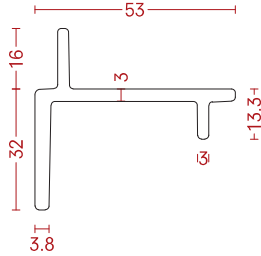

FF 5303TZ-01

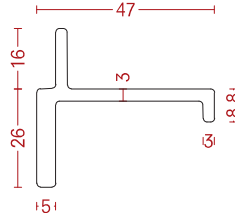

FF 4703TA-01

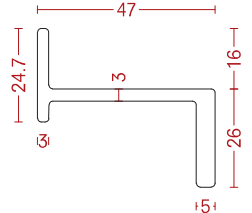

FF 4703ZA-01

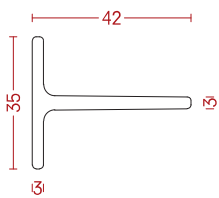

FF 4203TN-01

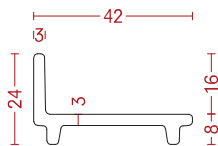

FF 4203LC-01

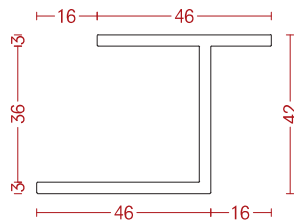

FF 4203RS-14

steel angular glazing beads - bar length 5800 mm

fixing screws

-01 Hot rolled steel -03 Stainless steel AISI 304 2B

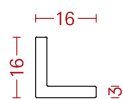

FV 1616A-01



D99867-03  
M4x6 mm  
100 PIECES



D99866-03  
M4x6 mm  
100 PIECES

rebate gaskets

internal profile gaskets

-81 black -84 black

-81 black

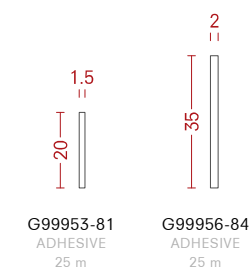

G99953-81  
ADHESIVE  
25 m

G99956-84  
ADHESIVE  
25 m



G99951-81  
ADHESIVE  
25 m

glass - internal/external gaskets

under glass gaskets

-79 white -82 black

-80 black

\*on request - minimum quantity required

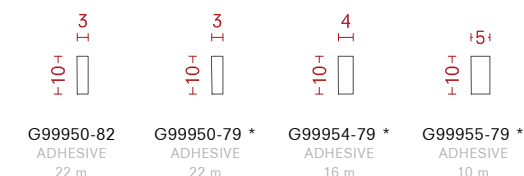

G99950-82  
ADHESIVE  
22 m

G99950-79 \*  
ADHESIVE  
22 m

G99954-79 \*  
ADHESIVE  
16 m

G99955-79 \*  
ADHESIVE  
10 m



G99952-80  
ADHESIVE  
25 m

end pieces for second leaf

-12 Bright steel

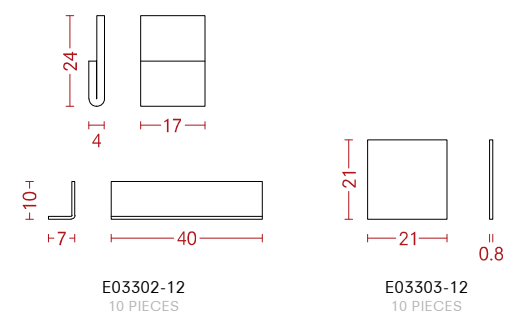

E03302-12  
10 PIECES

E03303-12  
10 PIECES

automatic drop seal

-62 PVC

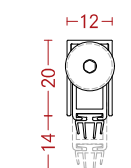

G995XX-62  
AUTOMATIC  
DROP SEAL  
1 PIECE

Code	Length	Can be shortened
G99501-62	330 mm	50 mm
G99502-62	430 mm	135 mm
G99503-62	530 mm	200 mm
G99504-62	630 mm	200 mm
G99505-62	730 mm	200 mm
G99506-62	830 mm	200 mm
G99507-62	930 mm	200 mm
G99508-62	1030 mm	200 mm
G99509-62	1130 mm	200 mm
G99510-62	1230 mm	200 mm





W40 FIRE

# open ing types

# W40 FIRE

examples: hinged door

scale 1:2

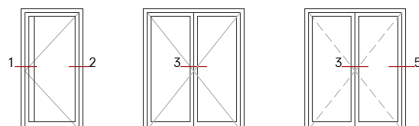
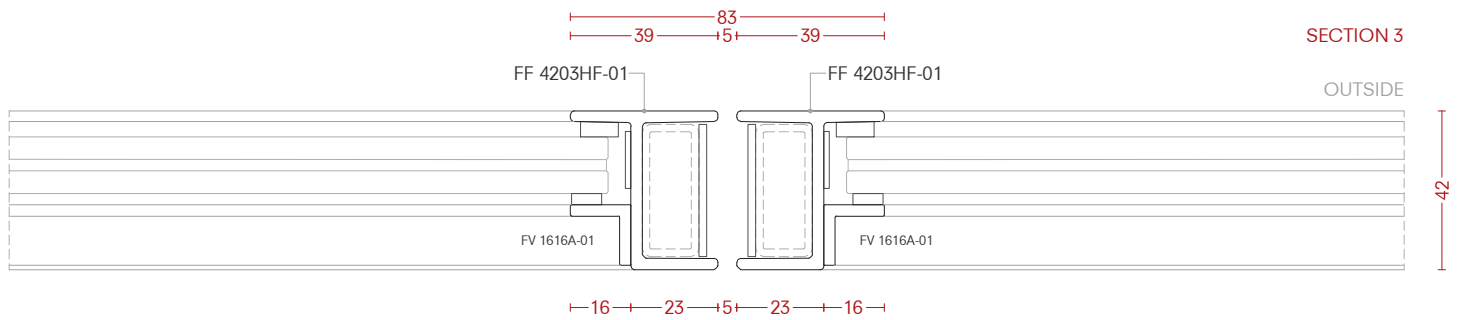
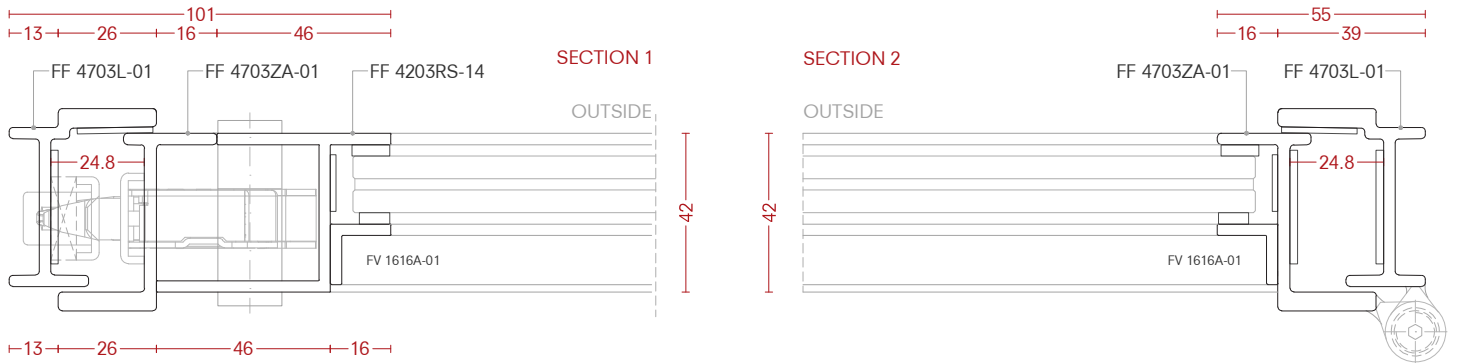

examples: hinged door, fixed

scale 1:2

